

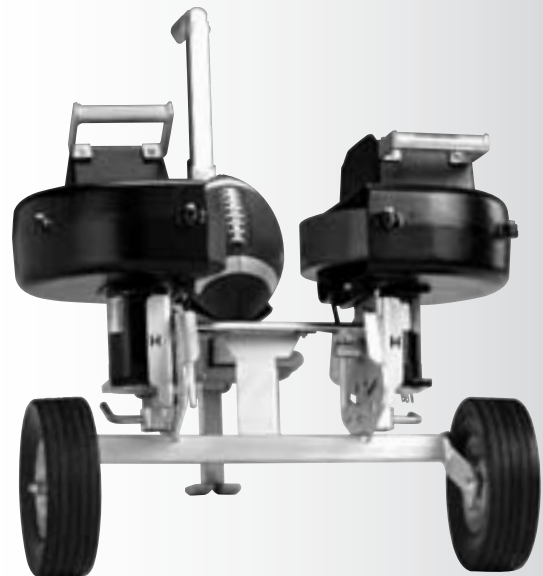

FOOTBALL MACHINE

FOOTBALL

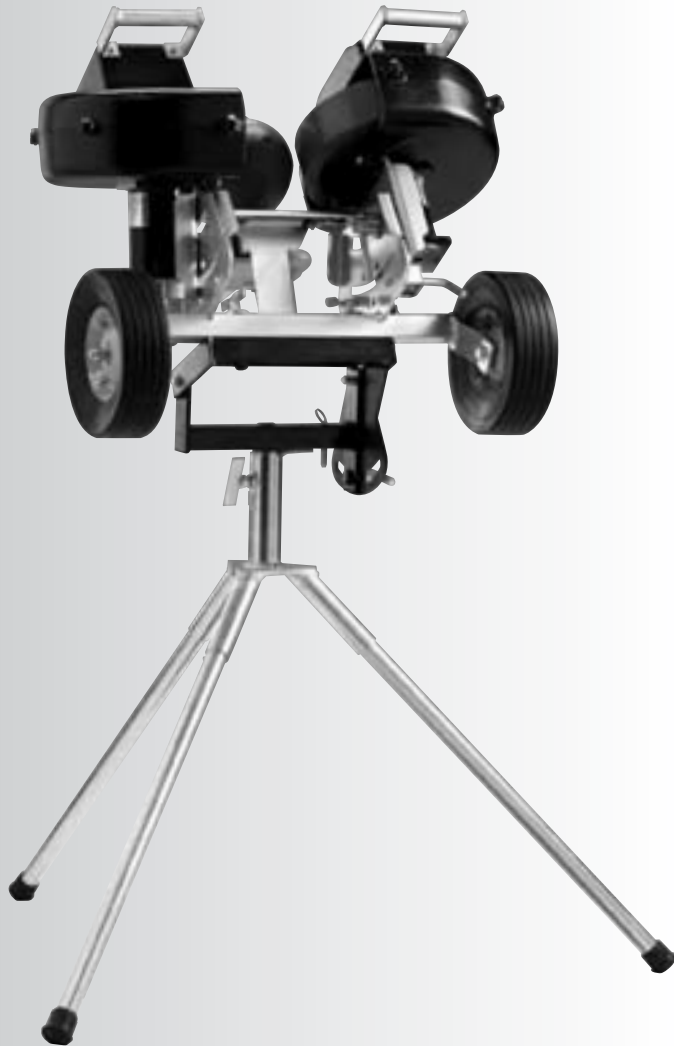

SNAP ATTACK™ FOOTBALL MACHINE
PATENTS APPLIED FOR

INSTRUCTION MANUAL

Includes: SETUP · OPERATION · USE & CARE · SERVICE

INSTRUCTION MANUAL PART NO. SNA-100



SPORTSATTACK LTD.
800.717.4251
www.sportsattack.com

WARRANTY STATEMENT

All sports training equipment manufactured by SPORTS ATTACK LTD. is warranted against defects in materials and workmanship for a period of five (5) years from the date of original purchase, with the following exceptions:

Throwing Wheels are warranted for one (1) year;
Electronic Controller is warranted for one (1) year; and,
Throwing Wheel Motors are warranted for one (1) year.

Should such equipment be found to be defective, SPORTS ATTACK LTD. will, at its option and sole discretion provide at no cost to the purchaser new or rebuilt replacements for defective parts and will pay the pre-approved labor charge to repair the product for the duration of the warranty period only.

THE FOREGOING OBLIGATION IS EXPRESSLY GIVEN IN LIEU OF ANY OTHER WARRANTIES, EXPRESSED OR IMPLIED, INCLUDING ANY IMPLIED WARRANTY OF MERCHANTABILITY OR FITNESS FOR A PARTICULAR PURPOSE, WHICH ARE HEREBY EXCLUDED.

SPORTS ATTACK LTD. SHALL NOT BE LIABLE FOR INDIRECT, INCIDENTAL OR CONSEQUENTIAL DAMAGES OR LOSSES FROM ANY CAUSE WHATSOEVER.

This warranty is void if the equipment has been misused, misapplied, improperly assembled, or modified without the express written permission of Sports Attack Ltd. In addition, this warranty does not apply to damage in transit, in any accident unrelated to the direct operation of the equipment, or by fire, flood or act of God.

To obtain warranty service during the warranty period:

1. Have the date of purchase and serial number ready (see page 3 for the location of the serial number).
2. Call the Customer Service Department at **1-800-717-4251**
3. Identify the product and describe the problem.

A Customer Service Representative will help you to correct the problem and send replacement part(s) if necessary. An INVOICE will be sent if any parts need to be exchanged. To clear the invoice, return, **prepaid and within 30 days**, the defective parts as detailed on the invoice to:

Sports Attack Ltd.
2805 U. S. 40
Verdi, NV 89439

SHIPPING DAMAGE CLAIMS PROCEDURE

NOTE: For your protection, please note that equipment in this shipment was carefully inspected and packaged by skilled personnel before leaving the factory.

Upon acceptance of this shipment, the transportation company assumes full responsibility for its safe delivery.

IF SHIPMENT ARRIVES DAMAGED:

1. **VISIBLE LOSS OR DAMAGE:** Be certain that any visible loss or damage is noted on the freight bill or express receipt, and that the note of loss or damage is signed by the delivery person.
2. **FILE CLAIM FOR DAMAGE IMMEDIATELY:** Regardless of the extent of the damage.
3. **CONCEALED LOSS OR DAMAGE:** If damage is unnoticed until the merchandise is unpacked, notify the transportation company or carrier immediately, and file "CONCEALED DAMAGE" claim with them. This must be done within fifteen (15) days from the date the delivery was made to you. Be sure to retain the container for inspection.

Sports Attack Ltd. cannot assume liability for damage or loss incurred in transit. We will, however, at your request, supply you with the necessary documents to support your claim.

To register the Warranty, please return the Warranty Registration Card to:

Sports Attack Ltd.
P.O. Box 1529
Verdi, NV 89439

For repairs and service after the warranty period, please call:

Sports Attack
Customer Service Dept.
Ph 1-800-717-4251
Fx (775) 345-2883

RETURNS

To return an item, please contact our Customer Service Department at 1-800-717-4251.

A 15% restocking fee will be charged for any items accepted for return. It is the customer's responsibility to handle the repacking and shipment (as well as all associated fees) back to Sports Attack.

No returns will be accepted after 30 days of receiving product.

TABLE OF CONTENTS

Warranty Statement	xi
Safety Instructions	2
SNAP ATTACK™ FOOTBALL MACHINE OPERATION	
Component View	3
Set-up & Preparation	4-5
Shutting Down & Transporting	6-7
Passing, Punting, Kickoff and Snapping Adjustments	8-9
MAINTENANCE & SERVICE	
Care, Cleaning & Maintenance	10
Component Replacement	11-13
Exploded View	14
Parts List	15
Convert To Manual Mode	16
Drilling Practice	17
SPORTS ATTACK	
Product Line	18-19

INTRODUCTION

Thank You for purchasing this Sports Attack Ltd. equipment. **Your Snap Attack™ will be shipped in the right-hand spin position.**

Proper assembly, careful operation and consistent maintenance of this equipment will ensure that it gives you the very best performance and a long, economical service life.

This manual contains the information needed to properly setup Snap Attack™, and to use, care for and maintain Snap Attack™ in a manner which will ensure its optimum performance.



SAFETY INSTRUCTIONS

ELECTRICAL SAFETY

Use a 115 volt single phase 3-wire grounded power source.

Up to 200 ft. from power source, use a minimum #14/3 grounded 3-wire extension cord.

Over 200 ft. from power source, consult a licensed electrician for required power cord size.

OPERATING SAFETY

CAUTION: Never reach down near moving **Throwing Wheels** for any reason! If it is necessary to reach into the **Throwing Wheels**, **ALWAYS:**

1. Turn **speed dial** to "0".
2. Turn the **Power Switch** "OFF".
3. Unplug Snap Attack™ from power source.
4. Wait until the **Throwing Wheels** have come to a complete stop before reaching hands or fingers anywhere near the **Throwing Wheels**.

CAUTION: Carefully check Snap Attack™ for completeness and condition before connecting to electrical power:

Carefully check the **Throwing Wheels** frequently for cleanliness, chips and cracks. Do not use the machine if the **Throwing Wheels** are damaged, or if chips or cracks appear in the **Wheels**. (For damage within warranty period, see Warranty Statement, page xi.)

ALWAYS set the **Speed Control** to "0" before connecting the machine to power. Check that the **Speed Control** is at "0" before turning the **Throwing Wheels** "ON".

Do not allow anyone to walk in front of the machine if it is connected to electrical power.

CAUTION: DO NOT plug in or energize this equipment until all Assembly Instructions and Operation Instructions are read and followed.

BALL SELECTION

Balls must be official size and consistent in type to produce repeatability.

Never use wet or damp balls! Ball air pressure must be between 10-12 lbs.



Distance	Air Pressure
70-90 yds.	9-11 lbs.
55-70 yds.	7-8 lbs.
40-55 yds.	5-6 lbs.

Slippage occurs at higher wheel speeds with lower air pressure. We recommend higher air pressure to prevent slippage.

WARNING

PERSONAL INJURY HAZARD

Carefully read all instructions in this manual, and all labels and warnings on Snap Attack™ before using this machine.

Use machine only under adult supervision. Failure to operate Snap Attack™ as described in this manual can result in severe personal injury or death.

ELECTRICAL SHOCK HAZARD

Snap Attack™ must be connected to a properly grounded electrical receptacle.

Do not operate on wet ground.

CAUTION

PERSONAL INJURY HAZARD

Keep hands away from **Throwing Wheels** anytime the machine is connected to a power source.

Carefully check Snap Attack™ for completeness and condition before connecting to electrical power.

EQUIPMENT ELECTRICAL DAMAGE

Keep hands away from **Throwing Wheels** anytime the machine is connected to a power source.

Carefully check Snap Attack™ for completeness and condition before connecting to electrical power.

COMPONENT VIEW WITH STAND

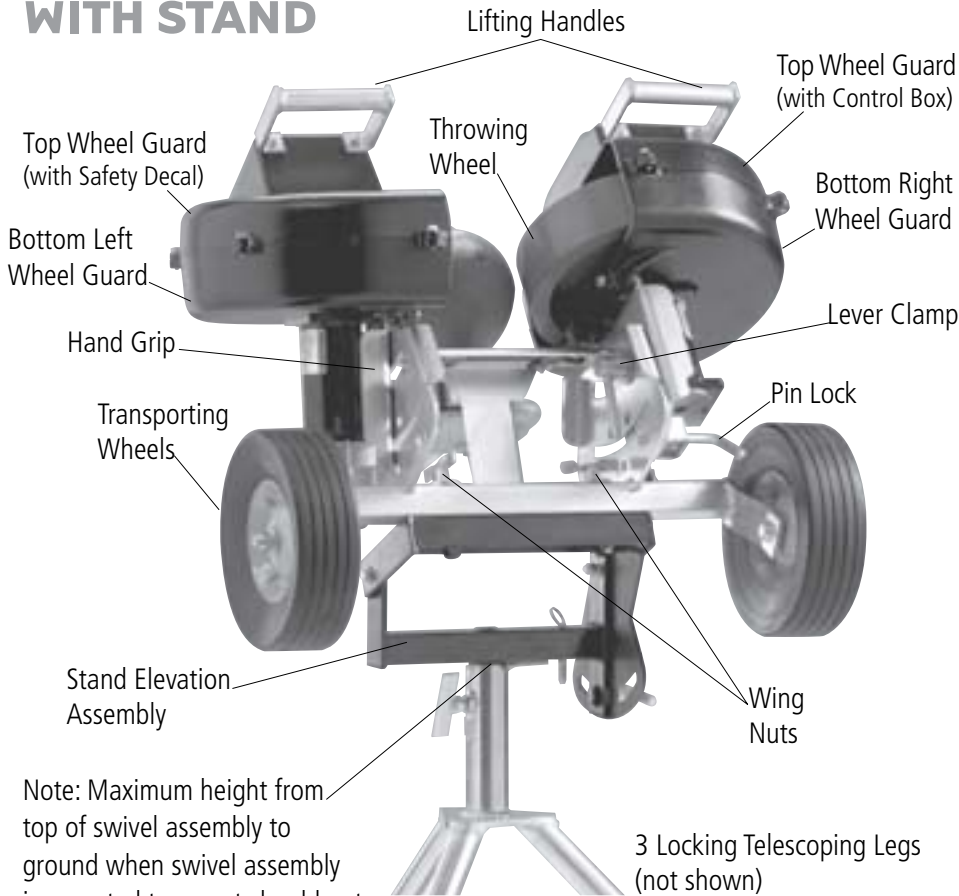

Note: Maximum height from top of swivel assembly to ground when swivel assembly is mounted to a post should not exceed 34", see page 18.

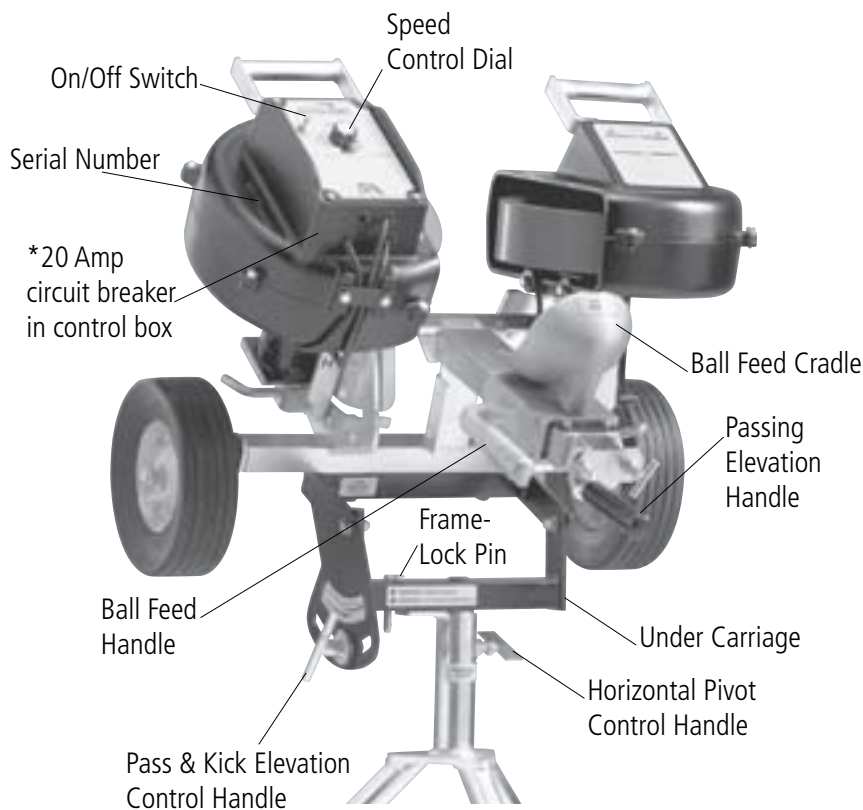

ADDITIONAL INFORMATION

If you have any questions regarding the safe operation of this equipment, please call:

Sports Attack Customer Service:
1-800-717-4251 or
775-345-2882

GENERATOR INFORMATION

1. Snap Attack™ requires a generator capable of providing clean electricity (inverter technology) of a minimum 1000 watts at 120 volts 60hz.
2. Be sure the **Power Switch** is "OFF" before plugging Snap Attack™ into the generator.
3. Start the generator and allow it to reach full speed before turning the **Power Switch** "ON".

IMPORTANT: Generator speed fluctuations can damage the electronic speed control. Maintain adequate fuel in the generator at all times.

4. Turn the **Power Switch** "OFF" before shutting off the generator and before unplugging Snap Attack™.

WITHOUT STAND

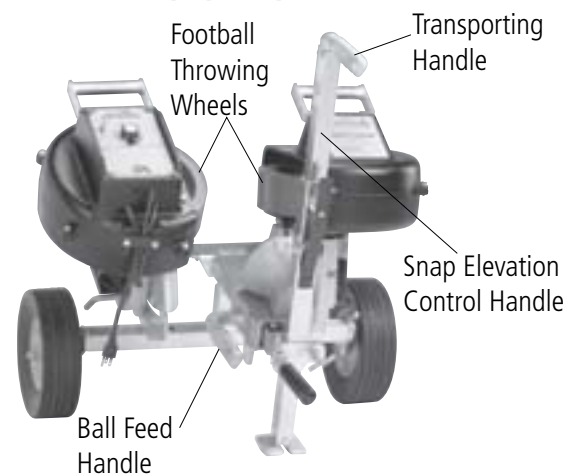

SET-UP & PREPARATION

USING THE SNAP ATTACK™ ON THE GROUND AS A CENTERING MACHINE

Snap Attack™ can be used in one of two modes. The first is when it is used on the ground to perform as a centering machine. The second is when it is used on its stand to perform as a quarterback when throwing passes or as a kicker or punter.

A. Setting machine up to perform as a centering machine

1. If machine is attached to stand:
 - a. Tip machine up and over onto the **Wheel Guards** (See Figure 1).
 - b. Unsocket the three legs and remove wing nuts (See Figure 2) and store wing nuts on same bolts.
 - c. Remove machine from stand.
2. Open rear leg support latch and insert rear leg support (See Figure 3).
3. Close latch over rear leg and tighten with wing nut (See Figure 4).
4. Tip machine back onto rear leg.
5. Point machine to desired direction.
6. Adjust angle by using your left hand to grab the passing handle and right hand to depress and adjust into 1 of 10 positions (See Figure 8 on page 7).
7. Turn machine on and turn **Wheel Speed Control Knob** to approximate speed.
8. Set ball carefully into **Ball Cradle** and feed ball into **Throwing Wheels**.
IMPORTANT! For tightest spiral slide **Ball Cradle** gently, allowing wheels to capture & impel ball. Do not jam cradle and ball into machine!
9. Adjust elevation and wheel speed until exact spin is attained (See Figure 8 on page 7).

SAFETY HINT

When lowering or lifting, Snap Attack™ keep your back straight and lift with your legs. Be ready to grab the **Wheel Guard** and guide Snap Attack™ into the upright position.

WARNING

HAZARD FROM HIGH-SPEED PROJECTILES

Being struck by a thrown ball can cause serious injury or death. Make sure that no one steps in front of Snap Attack™ while it is connected to electric power.

Clear everyone away from machine before connecting Snap Attack™ to electric power.



Figure 1
Use handles to lift or lower the Snap Attack™.



Figure 2
Remove wing nuts.



Figure 3
Open latch to insert rear leg support.



Figure 4
Close latch and tighten wing nut.

SET-UP & PREPARATION

USING THE SNAP ATTACK™ ON THE STAND TO THROW PASSES OR KICKS

IMPORTANT! Lock Pin must be removed (See Figure 5) and stored in adjacent hole to left. This will allow machine to pivot horizontally.

IMPORTANT! For maximum distance, balls must be properly inflated. See chart at bottom of page 2.

A. Setting machine up

1. If machine is in the centering mode, tilt machine up onto **Wheel Guards**.
2. Using wing nuts (See Figure 2 on page 4) which are stored on bolts, attach **Throwing Head** to **Undercarriage**, tighten wing nuts securely to passing stand (See Figure 6).
3. Insert 3 legs into sockets.
4. Using lifting handles (See Figure 1 on page 4) tilt machine up onto all three tripod legs.
5. Remove lock pin and store in adjacent hole to left (See Figure 5).
6. Loosen **Horizontal Control Handle** (See Figure 5).
7. Loosen **Stand Elevation Handle** (See Figure 7).
8. Plug machine into power source. (110v)
9. Turn **Power Switch** "ON."
10. Dial wheel speed to approximate speeds.
11. Continue throwing test balls and adjusting speeds until desired distance and speed is achieved.

Note: Maximum post height should not exceed 34" with the stand on the ground.
See page 18.

WARNING

PERSONAL INJURY HAZARD

Never reach down near **Throwing Wheels** for any reason! Always turn all three **Speed Control Dials** "OFF", turn the **Power Switch** "OFF", unplug Snap Attack™ from the power source and wait until the **Throwing Wheels** have come to a complete stop before reaching hands or fingers anywhere near **Throwing Wheels**.

Setting-up As A Passing Machine

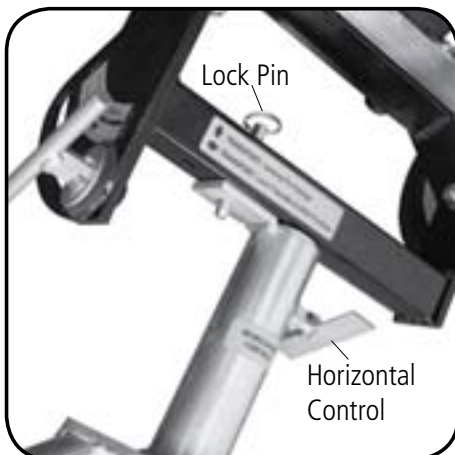

Figure 5
Lock Pin inserted to lock Throwing Head into position for transporting.



Figure 6
Attaching Throwing Head to Undercarriage.



Figure 7
Loosen Stand Elevation Handle.

SHUTTING DOWN & TRANSPORTING

TURNING SNAP ATTACK™ “OFF”

1. Set each **Speed Control Dial** to “0”.
2. Turn the **Power Switch** “OFF”.
3. Unplug Snap Attack™ from the power source.

WITH PASS AND PUNTING STAND

Transporting with stand

1. Be sure machine is turned “OFF” and wheels are not turning.
2. Unplug cord from extension cord, standard outlet or generator.
3. **Transport Lock Pin** must be inserted in hole to right, locking head into position for transporting (See Figure A).
4. Using the **Elevation Control**, tilt the **Throwing Head** up (to high position) and lock into place (See Figure B). This will facilitate transporting.
5. Using handles (See Figure C) tip machine up and over onto the **Wheel Guards**. Unsocket two lower (front) legs, leaving upper (rear) leg in socketed position.
6. Lift rear leg and roll machine (See Figure D).



Figure A
Lock Pin inserted to lock Throwing Head into position for transporting.



Figure B
Loosen Stand Elevation Handle.



Figure C
Use handles to lift or lower the Snap Attack™.



Figure D
Lift rear leg and roll. Shown being used with pass and punting stand.

SHUTTING DOWN & TRANSPORTING

TURNING SNAP ATTACK™ “OFF”

1. Set each **Speed Control Dial** to “0”.
2. Turn the **Power Switch** “OFF”.
3. Unplug Snap Attack™ from the power source.

AS A CENTERING MACHINE

Transporting without stand

1. Be sure machine is unplugged and turned “OFF” and **Wheels** are no longer turning.
2. Unplug cord from extension cord, standard outlet or generator.
3. Using **Spring Loaded Handle** (See Figure 8) lift **Elevation Handle** up to highest point.
4. Use **Elevation Handle (Spring Loaded Handle)** to roll machine (See Figure 9).



Figure 8
Extend handle to highest point.



Figure 9
Use Spring Loaded Handle to transport.



PASSING, PUNTING, KICKOFF & SNAPPING ADJUSTMENTS

The Snap Attack™ is able to simulate both a left-hand and right-hand spin.

For Right-Hand Spin

1. Loosen **Lever Clamp** a half turn.
2. Pull **Locating Pin** out of hole and start to pivot the motor using the **Hand Grip (H)**.
3. Release **Locating Pin**.
4. Continue pivoting motor until **Locating Pin** snaps into desired position: R.
5. **IMPORTANT!** Tighten **Lever Clamp** securely after pin snaps into place.
6. Repeat procedure on opposite side so that the pin is in the "R" position on both **Smile Plates**.

For Left-Hand Spin

1. Loosen **Lever Clamp** a half turn.
2. Pull **Locating Pin** out of hole and start to pivot the motor using the **Hand Grip (H)**.
3. Release **Locating Pin**.
4. Continue pivoting motor until **Locating Pin** snaps into desired position: L.
5. **IMPORTANT!** Tighten **Lever Clamp** securely after pin snaps into place.
6. Repeat procedure on opposite side so that the pin is in the "L" position on both **Smile Plates**.

For Kickoff

1. Loosen **Lever Clamp** a half turn.
2. Pull **Locating Pin** out of hole and start to pivot the motor using the **Hand Grip (H)**.
3. Release **Locating Pin**.
4. Continue pivoting motor until **Locating Pin** snaps into desired position: K.
5. **IMPORTANT!** Tighten **Lever Clamp** securely after pin snaps into place.
6. Repeat procedure on opposite side so that the pin is in the "K" position on both **Smile Plates**.

Spiral Pass/Punt/Snap

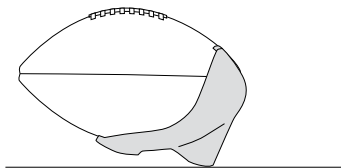

End-over-end Kickoff

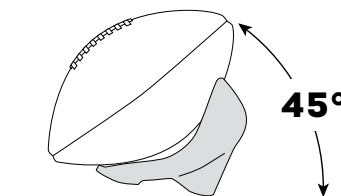

Smile Plate

Locating Pin Holes for both right- and left-hand motors.

R = Right-hand Spirals

L = Left-hand Spirals

K = Kickoff

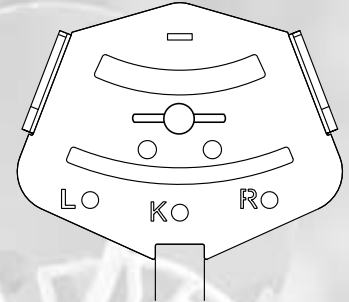

PASSING, PUNTING, KICKOFF & SNAPPING ADJUSTMENTS (CONT'D)

For Right-Hand Spin (Spiral)

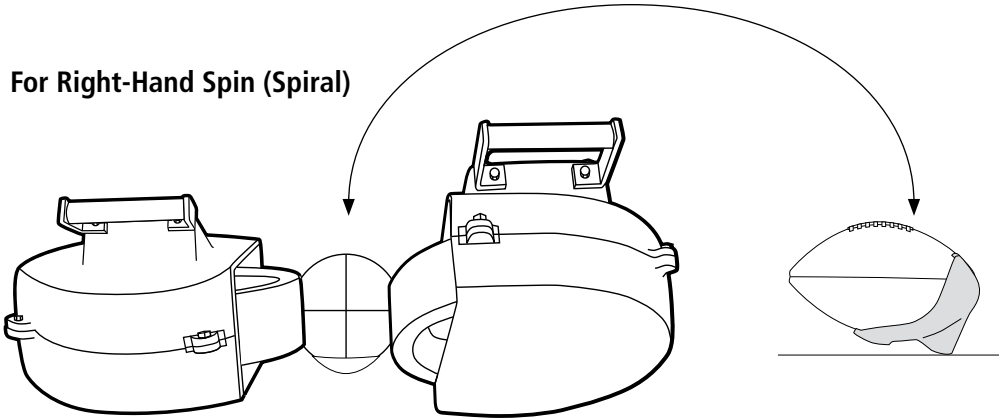

For Left-Hand Spin (Spiral)

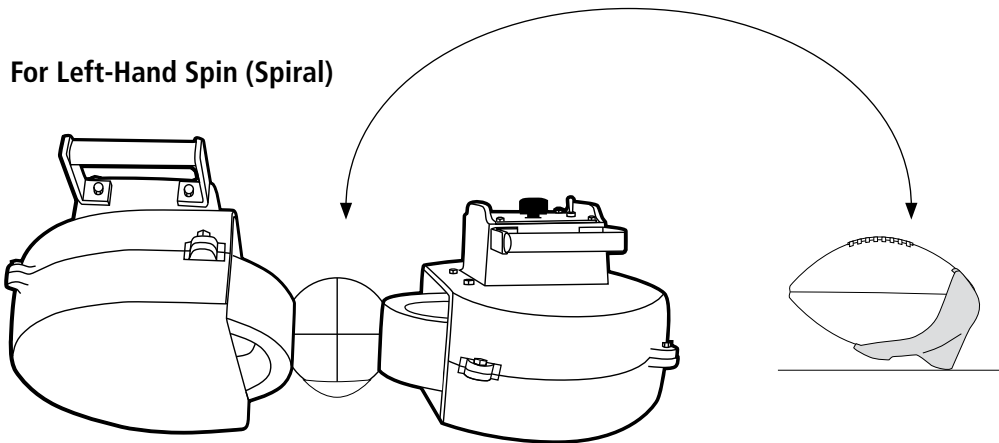

For Kickoff (End-over-end)

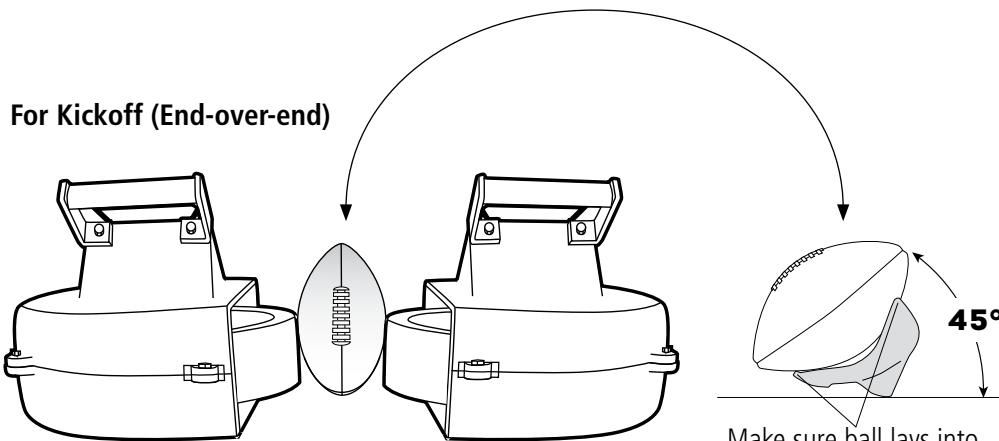

Make sure ball lays into molded groove on either end of ball cradle at approximately 45° angle.

Pin Lock position on Smile Plate.

Please be sure Pin Locks on both Smile Plates are in the same position.

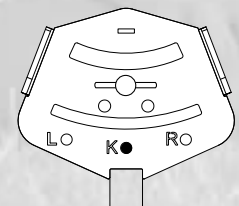
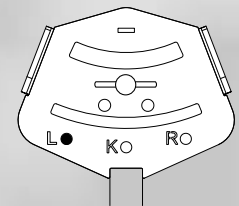
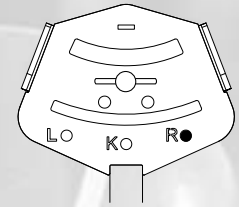

CARE, CLEANING & MAINTENANCE

LUBRICATION (once per season, or as required):

1. Pass & Kick Elevation Control Handle
Apply fresh grease to threads.
2. Horizontal Swivel Lock
 - a. Completely remove the **Horizontal Swivel Lock**. Clean all old grease, dirt, etc. from the threads.
 - b. Wipe the threads with a very small amount of fresh grease.
 - c. Reinstall.
3. Throwing Wheel Motors
Motors are sealed and require no lubrication.

THROWING WHEEL MOTORS

Motors are sealed and require no lubrication.

Check bolts for tightness once a season. Tighten bolts securely, but do not over-tighten. See page 11.

CLEANING THE THROWING WHEELS

The **Throwing Wheels** must be kept clean to maintain accuracy. Clean the wheels periodically to control the build-up of grass and dirt.

1. Turn the **Power Switch** "OFF" and allow the wheels to come to a complete stop. Unplug Snap Attack™ from electric power.
2. Dampen a rag with soap and water. Turn the **Throwing Wheel** by hand and scrub the wheel until the build-up is removed. For very heavy build-up, a synthetic scouring pad, such as a Scotch-Brite® scouring pad, may be used sparingly.

EXAMINE THE MACHINE

Examine Snap Attack™ for condition and completeness before every use:

1. **Throwing Wheels** must be tight on the motor shafts. Check that the four bolts holding the motor to the **Throwing Head Assembly** are tight.
2. **Wheel Guard** and **Ball Cradle** must be securely fastened.

CAUTION

PERSONAL INJURY HAZARD

Never attempt to clean the **Throwing Wheels** while they are turning. Rags or implements caught in spinning wheels can cause serious injury.

Unplug the machine before cleaning the wheels or performing any service.

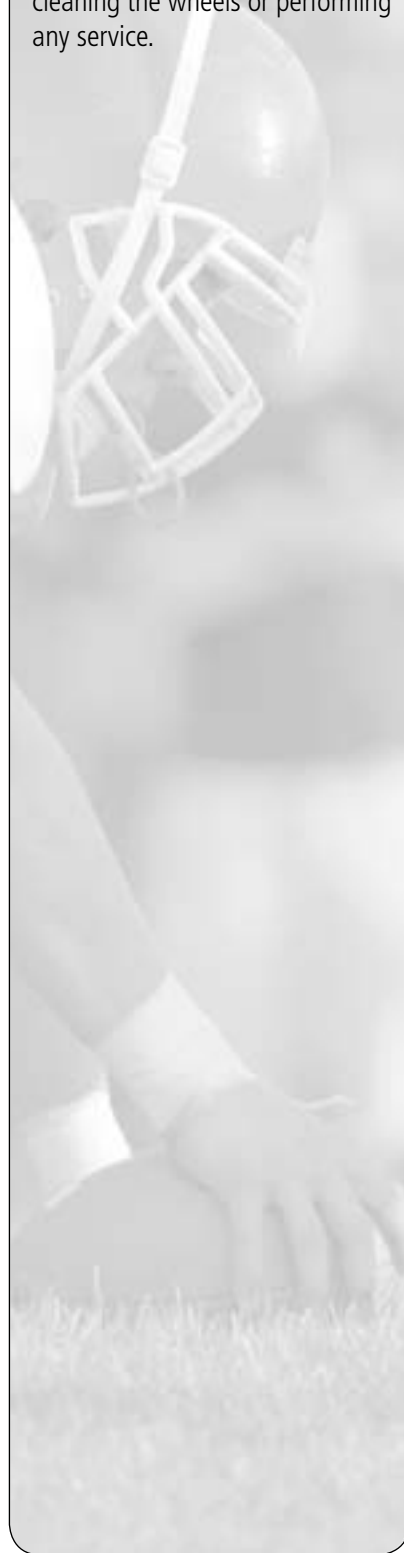

COMPONENT REPLACEMENT

THROWING WHEEL REPLACEMENT

1. Turn the **Throwing Wheels** "OFF" and unplug the power cord. Remove 4 bolts holding the top wheel guard to the bottom wheel guard.
2. Hold the wheel so that it cannot move. Turn the keyway retaining bolt counter-clockwise using a box end wrench (See Figure 10).
Suggestion: If the bolt is too tight, give the opposite end of the wrench a series of light taps with a hammer making sure the wrench remains on the bolt.
3. Remove the bolt and washers.
4. Work the wheel off of the motor shaft. Be sure to catch the key as it is freed from the keyway.
5. **Ball Throwing Wheels** are machine balanced. Small holes in the side of the wheel are applied at the factory and are normal.

Reassemble in reverse order.

- a. Install wheel to motor shaft with key slots aligned.
- b. Be sure the key is in place, and inserted so that it is flush with the boss at the wheel center.
- c. Be sure the **Washer** and **Lock Washer** are installed in the right order, and that the keyway retaining bolt is tightened.
- d. Test the wheel by spinning it by hand and making sure that it spins freely without wobble before turning the unit "ON".
- e. Be sure the top **Wheel Guard** is properly and securely reinstalled.

Note: Check bolts for tightness once a season. Tighten bolts securely, but do not over-tighten.



Figure 10
Hold wheel while loosening bolts.

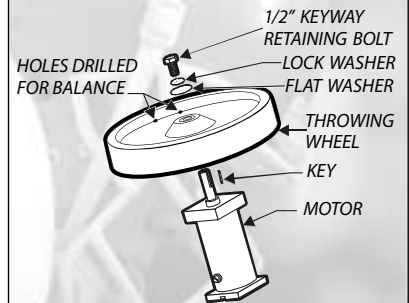

COMPONENT REPLACEMENT

MOTOR REPLACEMENT

1. Turn the Power Switch "OFF" and unplug the power cord.
2. Remove **Top Wheel Guard**.
3. Remove the **Throwing Wheel** (See page 11).
4. Remove **Bottom Wheel Guard**.
5. Remove four screws holding the controller into the control box casting. Note the position of the motor wires on the controller, then disconnect the wire for the motor to be replaced (See Figure 14 on page 13).
6. Note the routing of the motor wires. Loosen wire clamps and pull wire away from machine.
7. Pivot motor to "K" position. The 2 - $\frac{1}{4}$ " x $\frac{3}{4}$ " coarse Allen sockethead bolts can only be accessed in the "K" position (See Figure 11).
8. To remove motor, remove the 2 - $\frac{1}{4}$ " x $\frac{3}{4}$ " coarse Allen flat socket cap screws using a $\frac{5}{32}$ " Allen wrench. Then remove the 2 - $\frac{5}{16}$ " x 1" coarse thread bolts using a $\frac{1}{2}$ " socket.
9. Reassemble in reverse order.

Note: Check bolts for tightness once a season. Tighten bolts securely, but do not over-tighten.

Motor Replacement Tools

When replacing the motor, you will see two sets of bolts:

2 - $\frac{1}{4}$ " x $\frac{3}{4}$ " coarse Allen flat socket cap screw

2 - $\frac{5}{16}$ " x 1" coarse thread bolts

The Allen wrench needed for the $\frac{1}{4}$ " Allen screw is a $\frac{5}{32}$ ".

The wrench or socket size needed for the $\frac{5}{16}$ " bolt is a $\frac{1}{2}$ ".



Removing Bottom Wheel Guard, shown using a $\frac{1}{2}$ " socket.

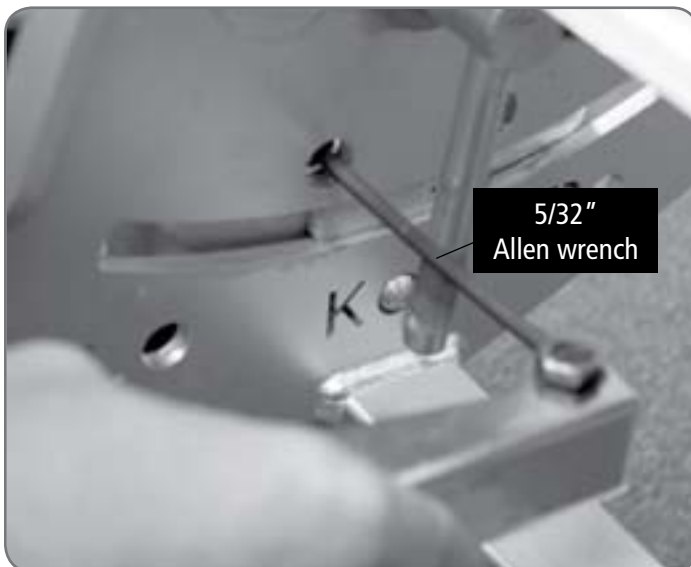

Figure 11 Shown using a $\frac{1}{2}$ " socket.



Figure 12 Shown using a $\frac{1}{2}$ " socket.

COMPONENT REPLACEMENT (continued)

CONTROLLER REPLACEMENT

1. Turn the **Power Switch** "OFF" and unplug the power cord.
2. Remove knob from the controller.
3. Remove four screws holding controller faceplate into main casting. Note the position of the main power and motor wires on the controller, then disconnect the wires. See Figure 14 for the two motor wires. See Figure 13 for the main power cord wires.
4. Loosen the nuts holding the speed control shaft (potentiometer) to the faceplate, then remove the controller.

Reassemble in reverse order.

Be sure wires are correctly reinstalled. Motor wire connectors are different sizes. Be sure they are installed on the correct size terminal. See Figure 14 for the two motor wires and Figure 13 for the power cord wires.

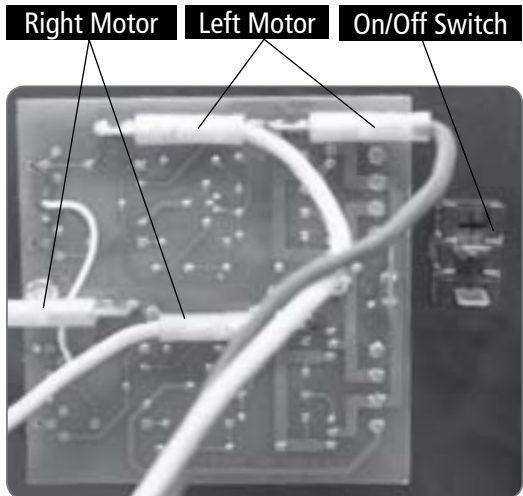

Figure 14 Wiring diagram for all two motors.

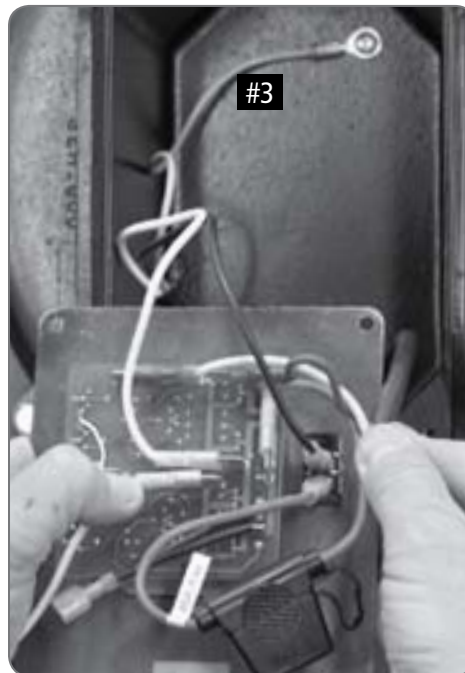

Figure 15 Wiring for all two motors.

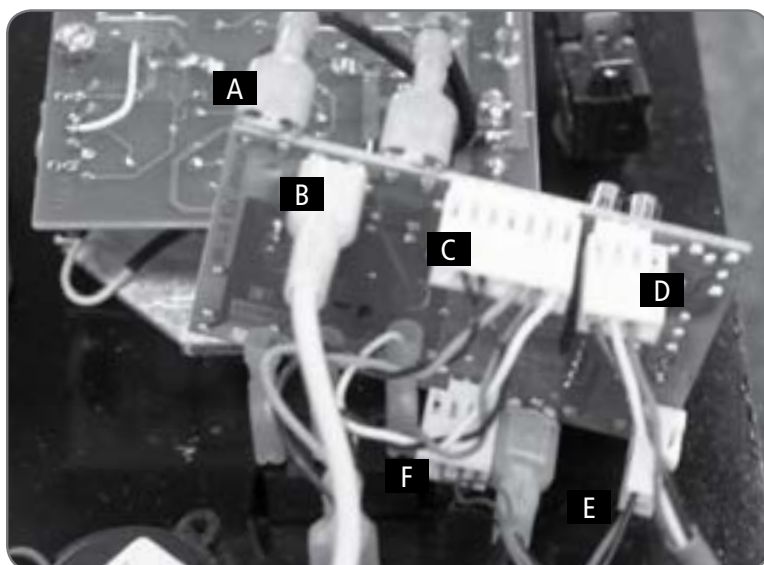

Figure 16 Wiring diagram for Automatic Model.

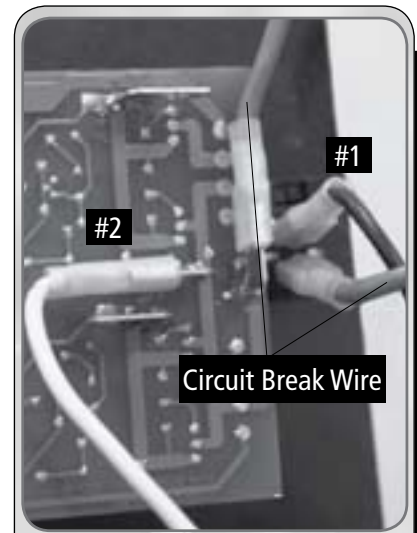

Figure 13

Power Cord Wire

- Black (#1)
On/Off switch
- White (#2)
N on green control board
- Green (#3)
Grounds to machine

Connecting Wires

Motor	Black Wire	White Wire
Right	A-	A+
Left	A+	A-

Left is the side with the Control Plate as you stand behind machine.

Black motor wires are $\frac{3}{16}$ " female disconnect and white wires are $\frac{1}{4}$ " female disconnect.

Automatic Model

- A Power to Remote Board
Wire colors: black & black
- B Ball Feed Motor
Wire colors: black & white
- C Auto Feed and Delay Switches
Auto Feed wire colors: orange & black
Feeder Delay wire colors: blue, white & black
- D Remote Receiver
Wire colors: red, black & white
- E Beeper
Wire colors: red & black
- F Sensor
Wire colors: black, blue & brown

EXPLODED VIEW - SNAP ATTACK™

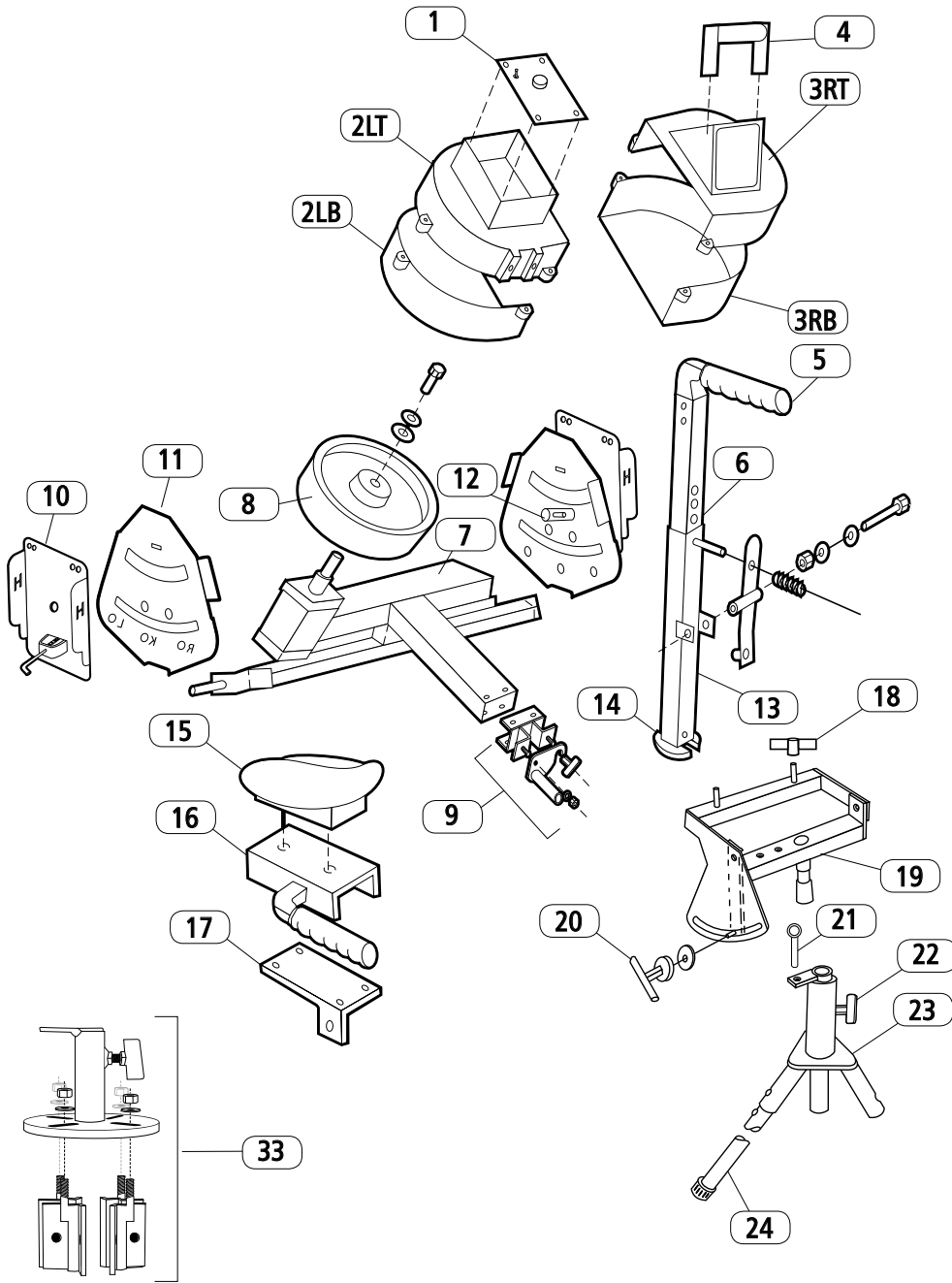

- 1 Control Plate
- 2LT Top Left Wheel Guard
- 2LB Bottom Left Wheel Guard
- 3RT Bottom Right Wheel Guard
- 3LT Lower Right Wheel Guard
- 4 Handle Assy
- 5 Handle
- 6 Elevated Bar Assy
- 7 Throwing Head Assy
- 8 Throwing Wheel
- 9 Snapping/Passing Elevation Assy
- 10 Motor Mount Plate with Pin
- 11 Smile Plate
- 12 Lever Clamp
- 13 Elevation Tube Assy
- 14 Foot
- 15 Ball Cradle
- 16 Upper Slide with Handle
- 17 Lower Slide
- 18 Wing Nut
- 19 Stand Elevation Assy
- 20 Stand Elevation Handle
- 21 Locking Pin
- 22 Horizontal Swivel Lock Handle
- 23 Swivel Assy
- 24 Leg

Automatic Model

- 25 Feed Motor Cover
- 26 Feed Motor
- 27 Feed Motor Plate
- 28 Crank Assy
- 29 Remote Control
- 30 Receiver
- 31 Lower Slide
- 32 O-Ring

Cart Clamp Kit (optional)

- 33 Clamp Kit

AUTOMATIC MODEL

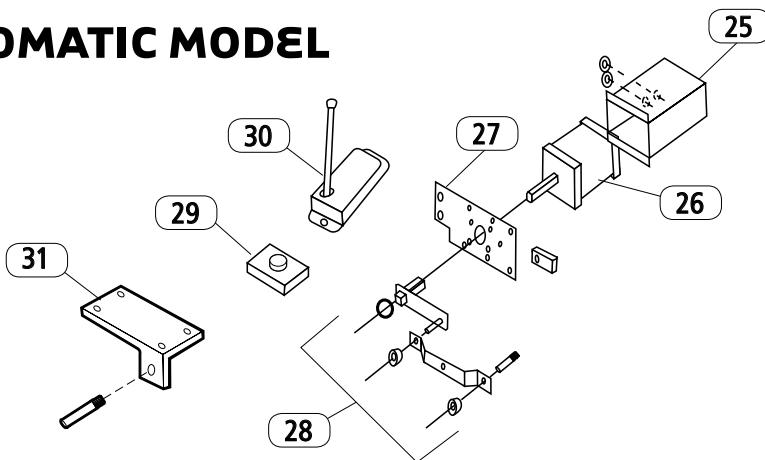

PARTS LIST

EM	PART NO.	DESCRIPTION	QTY PER
1	SNA-32	Control Plate	1
2LT	SNA-28	Top Left Wheel Guard	1
2LB	SNA-30L	Bottom Left Wheel Guard	1
3RB	SNA-26	Top Right Wheel Guard (with Safety Decal)	1
3LT	SNA-30R	Lower Right Wheel Guard	1
4	SNA-66	Handle Assy	1
5	SNA-20	Handle	1
6	SNA-14	Elevated Bar Assy	1
7	SNA-8	Throwing Head Assy	1
8	SNA-24	Throwing Wheel	1
9	SNA-11C	Snapping/Passing Elevation Assy	
10	SNA-9	Motor Mount Plate with Pin	2
11	SNA-9A	Smile Plate	2
12	SNA-9E	Lever Clamp	2
13	SNA-10	Elevation Tube Assy	1
14	SNA-33	Foot	1
15	SNA-41	Ball Cradle	1
16	SNA-40	Upper Slide with Handle	1
17	SNA-39	Lower Slide	1
18	SNA-59	Wing Nut	2
19	SNA-51	Stand Elevation Assy	1
20	SNA-61	Stand Elevation Handle	1
21	SNA-63	Locking Pin	1
22	SNA-48A	Horizontal Swivel Lock Handle	1
23	SNA-48	Swivel Assy	1
24	SNA-45	Leg	3
Automatic Model			
25	SNA-38	Feed Motor Cover	1
26	SNA-37	Feed Motor	1
27	SNA-64	Feed Motor Plate	1
28	SNA-29	Crank Assy	1
29		Remote Control	1
30		Receiver	
31	SNA-39	Lower Slide	1
Cart Clamp Kit (optional)			
33	SNA-47B	Clamp Base	1
34	SNA-47A	Clamps	4

To order additional parts,
please contact:

Sports Attack
Customer Service Dept.
1-800-717-4251



TO CONVERT FROM AUTOMATIC TO MANUAL MODE

WITH REMOTE

1. Remove 2 black rubber grommets (See Figure 18. Twist and pull. No tools required).
2. Slide **Linkage Arm** off the two metal studs (See Figure 19).
3. Place the **Linkage Arm** onto the single storage stud (use the center hole on **Linkage Arm**. See Figure 20).
4. Store both black rubber grommets on the same stud, to hold the **Linkage Arm** in place (See Figure 20).

To convert to Automatic Mode, reassemble in reverse order.

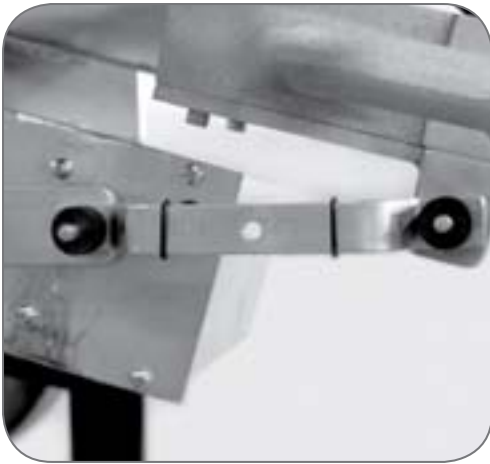

Figure 17 Linkage Arm in place.



Figure 18 Removing black grommets.

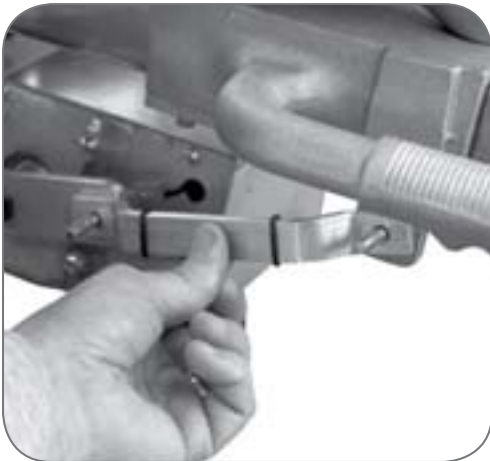

Figure 19 Sliding Linkage Arm off studs.



Figure 20 Storing Linkage Arm and grommets.

To order additional parts,
please contact:

Sports Attack
Customer Service Dept.
1-800-717-4251



Handle Conversion

HOW TO OPERATE IN AUTO MODE

With the remote, the coach can control the tempo of the practice. He can call for the ball at any instance from any location on the field.

- Three positions: instant, 5 and 10 second delays
- Instant position provides on-command ball delivery with remote
- 5 and 10 second delay switch allows punter or extra-point holder and kicker to load machine, then get into position to receive ball. Machine will snap ball automatically with or without the use of the remote.
- Punter, kicker or holder can work alone with live snaps.
- Coach can call for the snap in shotgun or pistol formation signal drills



Figure 21 Remote lets you control practice from any location.



ATTACHING OPTIONAL CART CLAMP

1. Insert **Clamp Bolt** through **Top Plate**. Loosely attach washer and nut. Finger tighten.
2. Put 3 bolts through sides of **Clamps**. Slide unit over post, then attach fourth bolt.
3. Center **Top Plate** to post. Begin tightening 4 **Clamps** to **Top Plate**, but do not completely tighten.
4. Begin to secure the 4 side bolts. Completely tighten.
5. Completely tighten 4 clamp nuts to **Top Plate**.

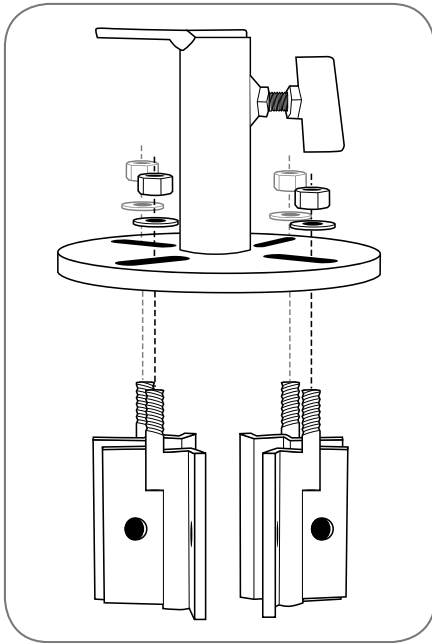

Figure 22 Insert Clamp Bolt through Top Plate.

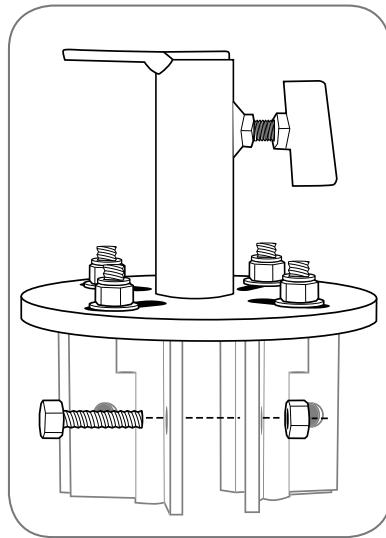

Figure 23 Put 3 bolts through sides of Clamps.



Figure 24 Slide unit over post and attach 4th bolt.

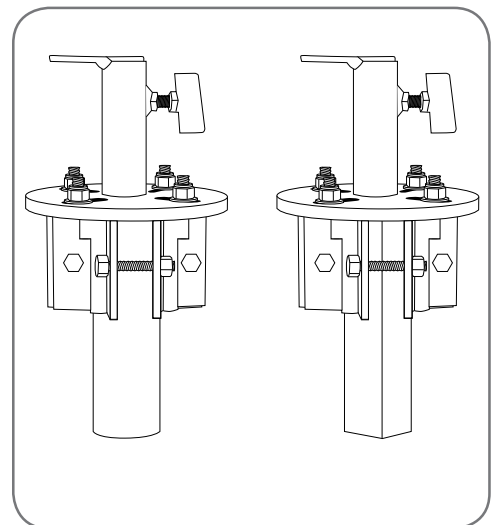

Figure 25 Clamp can be used on round or square posts.

Cart Clamp Kit

Item	Qty
Clamp	4
Top Plate	1
1/2-13x3 1/2 Bolts	4
1/2-13 Nylon Lock Nuts	8
1/2 SAE Plain Washers	4

Tools needed are either a $\frac{3}{4}$ wrench or socket wrench.

Note: Maximum post height should not exceed 34" with the stand on the ground. When attaching the option cart clamp, slide unit over post and dry fit to ensure that maximum post height from ground to top of the post does not exceed 34". If your post height exceeds 34", you should cut your post so that it complies with this measurement.

DRILLING PRACTICE

A. TYPICAL USES WITH STAND

1. Passing
 - a. Passing including deep passes, sideline routes, curls, hook and slants
 - b. Drills including interception, tip and defensive
 - c. Versus zone defenses
 - d. Prevent
 - e. Versus "Hail Mary"
2. Kicking
 - a. Long punt
 - b. Punt return
 - c. Kickoffs
 - d. Kicks including squib and onside

B. TYPICAL USES WITHOUT STAND

Transporting with stand

1. As a center when practicing in the shotgun or similar formation.
2. When practicing extra points/snapping to holder/to kick field goals.
3. When punting.

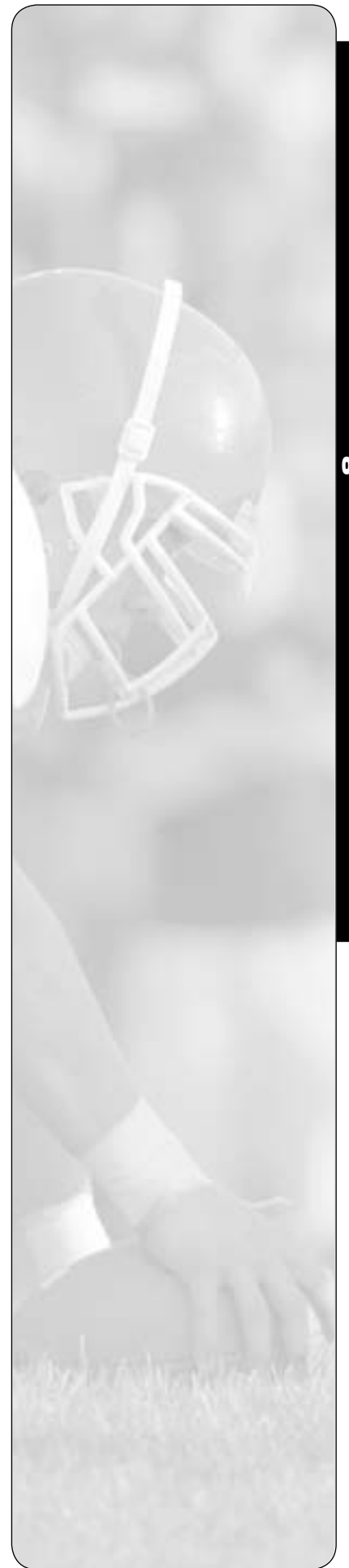

SPORTS ATTACK PRODUCTS

BASEBALL



HACK ATTACK



HACK ATTACK JR.

SOFTBALL



HACK ATTACK SOFTBALL



HACK ATTACK JUNIOR SOFTBALL (shown with optional feeder)



Please visit our web site www.sportsattack.com for information about Sports Attack sports training products, or call 1-800-717-4251 for complete information and specifications.

SPORTS ATTACK PRODUCTS

TENNIS



TENNIS ATTACK

FOOTBALL



SNAP ATTACK

VOLLEYBALL



ATTACK (shown with optional ball bags)



ATTACK II (shown with optional ball bags)



SKILL ATTACK



Please visit our web site www.sportsattack.com for information about Sports Attack sports training products, or call 1-800-717-4251 for complete information and specifications.